



EN14428 EN12150

- ES** Todas las mamparas han sido diseñadas y fabricadas de acuerdo con EN14428
Todos los cristales utilizados en nuestros productos están certificados y probados de acuerdo con EN12150
- EN** All shower products are designed and manufactured according to EN14428
All the glass used on the product are certified and tested according to EN12150
- FR** Toutes les parois ont été conçues et fabriquées conformément à EN14428
Toutes les verres utilisés dans nos produits sont certifiés et testés conformément à EN12150
- IT** Tutti i box doccia sono stati disegnati e fabbricati in accordo con EN14428
Tutti i cristalli utilizzati nei nostri prodotti sono certificati e collaudati in accordo con EN12150

MANUAL INSTRUCCIONES CRISTAL



IMPORTANTE

- ES** La etiqueta de tratamiento antical debe quedar instalada por dentro.
El acabado de serigrafía por fuera.
- EN** The anti-lime treatment sticker must be installed on the inside.
The printing glass finish outside.
- FR** L'étiquette de traitement anticalcaire doit rester installée à l'intérieur.
La finition de la sérigraphie à l'extérieur.
- IT** Il lato in cui è applicata la etichetta del trattamento anti calcare identifica la parte interna del cristallo.
Il lato serigrafato va esternamente.

- ES** MANUAL DE INSTALACIÓN
No tirar. Guardar el manual de instalación para un uso posterior.
- EN** INSTALLATION MANUAL
Do not discard. Save the installation manual for further use.
- FR** MANUEL D'INSTALLATION
Ne pas jeter. Garder le manuel d'installation pour un usage postérieur.
- IT** MANUALE DI INSTALLAZIONE
Non cestinare. Conservare il manuale di installazione per un utilizzo posteriore.

ATENCIÓN / ATTENTION

- ES** No utilizar productos de limpieza con componentes ácidos en cristales mate serigrafiados o cualquier acabado rugoso. Usar solo jabón pH neutro o alcohol.
- EN** Don't use abrasive products or cleaning products with acid components in print silked glasses or any rugged decoration. Use normal pH neutral soap or alcohol.
- FR** Ne pas utiliser de produits de nettoyage avec des composés acides dans les verres mats sérigraphiés ou n'importe quel finition rugueuse. Utiliser uniquement savon pH neutre ou alcool.
- IT** Non usare prodotti di igiene con componenti acidi su cristalli opachi, serigrafati o con qualunque finitura rugosa. Utilizzare unicamente sapone pH neutro o alcool.



- ES** Vinagre / Antical / Detergente
- EN** Vinegar / Anti-lime / Detergent
- FR** Vinaigre / Anticalcaire / Détergent
- IT** Aceto / Anti calcare / Detergente



- ES** Jabón pH neutro / Alcohol
- EN** pH neutral soap / Alcohol
- FR** Savon pH neutre / alcool
- IT** Sapone pH neutro / Alcool



IMPORTANT INFORMATION / INFORMACIÓN IMPORTANTE / INFORMATIONS IMPORTANTES / INFORMAZIONI IMPORTANTI

- EN**
- Always wear safety goggles and work gloves when installing or disassembling this product, especially when working with glass panels.
 - When handling, never rest the corner of the glass directly on the floor or hit the corner with any object. This can cause the glass to break.
 - Always have two persons to install or disassemble the shower.
 - Small children should never use the shower unsupervised or without proper instructions for safety use.
 - Small children should never hit, lean, or hang on the shower product. Nor should they do any inappropriate activity in the vicinity of the shower.
 - Tempered safety glass is designed to shatter into small tiny pieces when the glass is broken, this is to avoid serious injury.
- ES**
- Llevar gafas y guantes de seguridad durante la instalación o desmontaje de este producto, especialmente durante la manipulación de los cristales
 - Durante la manipulación, nunca dejar descansar las esquinas de los cristales directamente en el suelo o golpearlos con cualquier objeto. Puede provocar la rotura del cristal
 - Es conveniente que la instalación o el desmontaje sea llevado a cabo por dos personas.
 - Los niños no deben usar la ducha sin supervisión o sin apropiadas instrucciones de uso para sus seguridad
 - Los niños no deben, bajo ningún concepto, golpear, apoyarse o colgarse de los productos de ducha. De la misma manera, deberán realizar actividades inapropiadas en las inmediaciones de la mampara.
 - El cristal templado de seguridad ha sido diseñado para romper en pequeñas piezas con el objetivo de evitar daños mayores
- FR**
- Porter des lunettes et des gants de sécurité aux cours de l'installation de ce produit, en particulier pendant la manipulation des verres.
 - Pendant la manipulation ne jamais laisser reposer les coins des verres directement par terre ou les choquer avec n'importe quel objet. Cela peut provoquer la brisure du verre.
 - Il est souhaitable que l'installation ou le déballage soit réalisé par deux personnes.
 - Les enfants ne doivent pas, en aucun cas, choquer, s'appuyer ou se pendre des produits de douche. De la même manière ils ne devront pas réaliser des activités inappropriées à proximité de la paroi.
 - Le verre tempéré de sécurité a été conçu pour casser en petites pièces afin d'éviter de plus grands dommages.
- IT**
- Indossare occhiali e guanti protettivi durante l'installazione o smontaggio di questo prodotto, specialmente durante la manipolazione dei cristalli.
 - Non appoggiare mai gli angoli dei cristalli direttamente al suolo o colpirli con qualunque oggetto durante la manipolazione. Il cristallo potrebbe rompersi.
 - È conveniente che l'installazione o lo smontaggio siano eseguiti da due persone contemporaneamente.
 - I bambini non devono usare la doccia senza la supervisione di un adulto o senza le dovute istruzioni di sicurezza
 - I bambini non devono colpire, appoggiarsi o appendersi agli elementi della doccia. Non dovranno, inoltre, realizzare attività inappropriate in prossimità del box doccia.
 - Il cristallo temperato di sicurezza è stato disegnato affinché si rompa in piccoli pezzi onde evitare danni maggiori.

Body part / Despiece

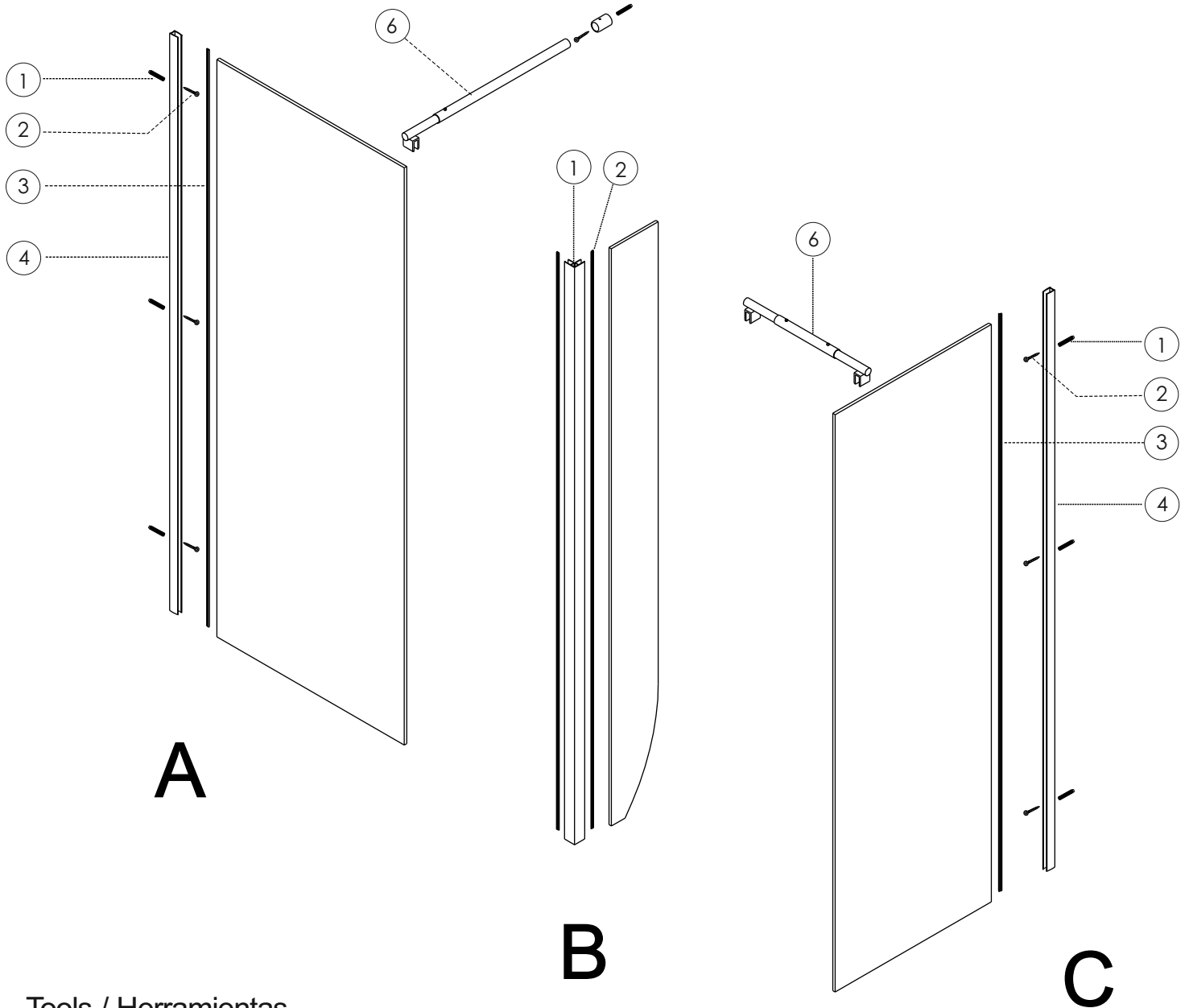

Tools / Herramientas

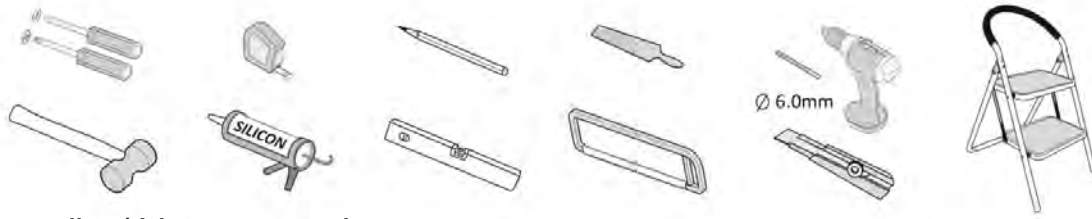

Hardware list / Lista accesorios

A		
Num. Number	Pic Imagen	Cant. Qty.
1		4
2		4
3		1
4		1
6		1

B		
Num. Number	Pic Imagen	Cant. Qty.
1		1
2		2

C		
Num. Number	Pic Imagen	Cant. Qty.
1		3
2		3
3		1
4		1
6		1

1

A

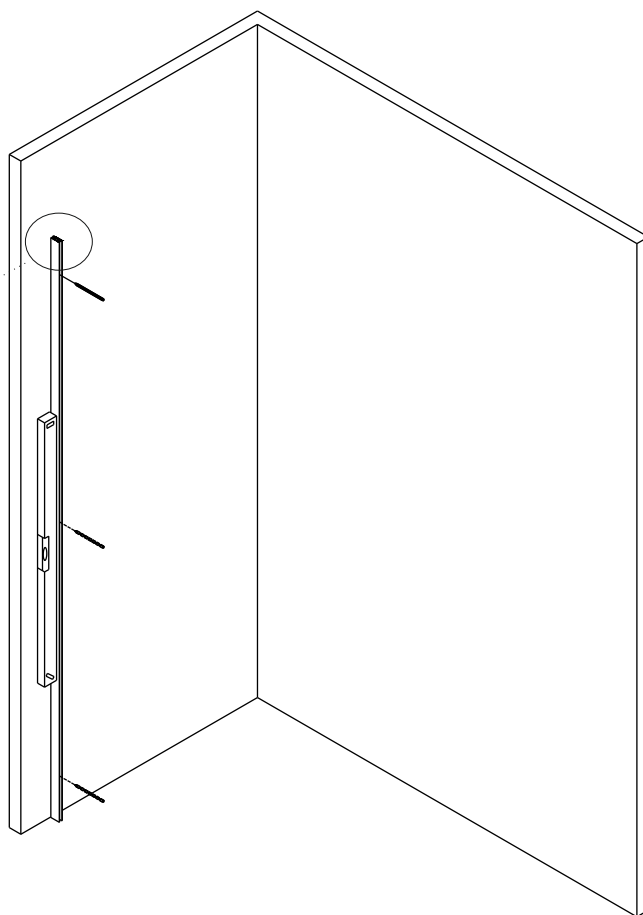
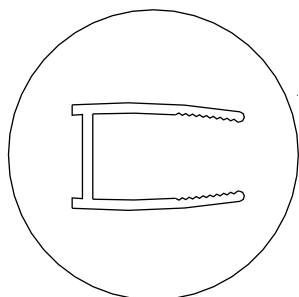

2

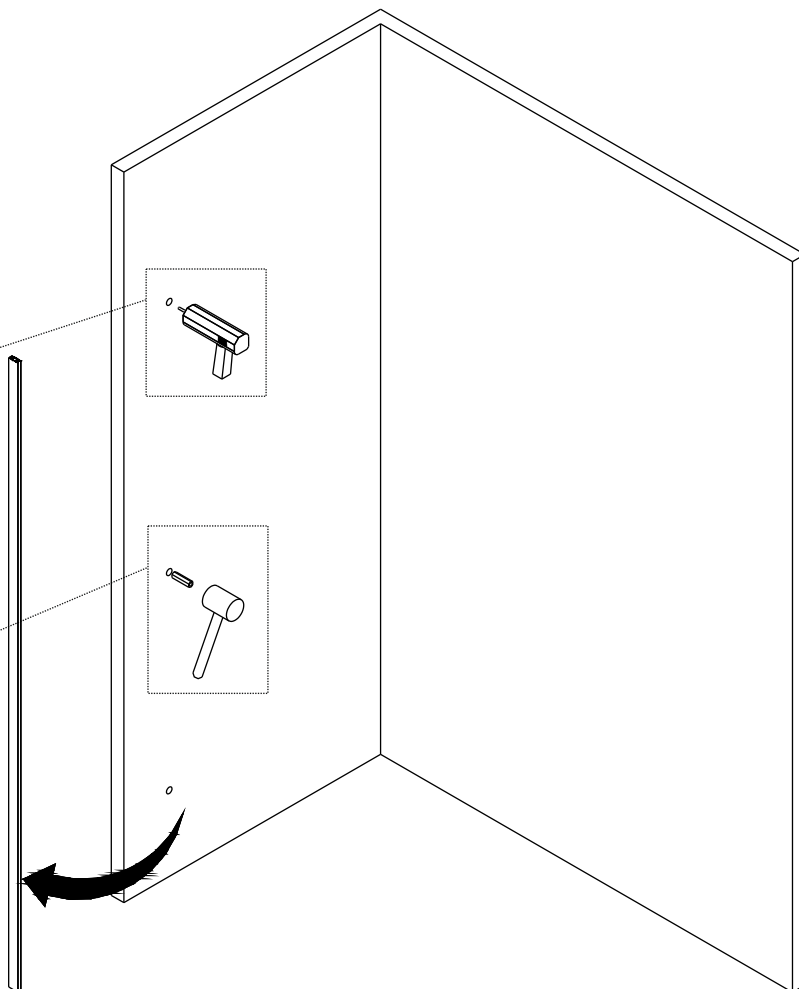
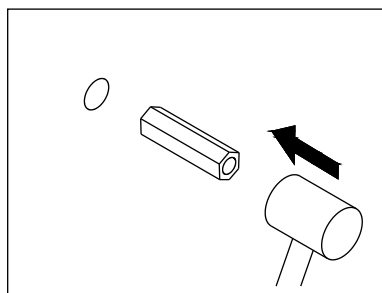
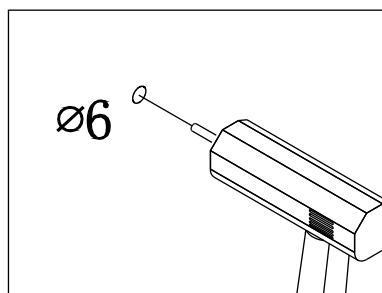

3

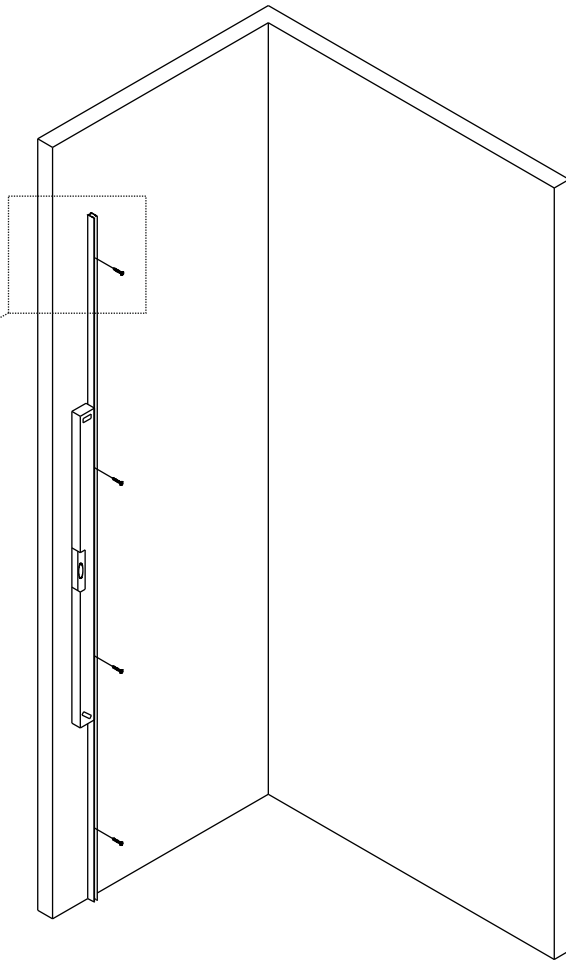
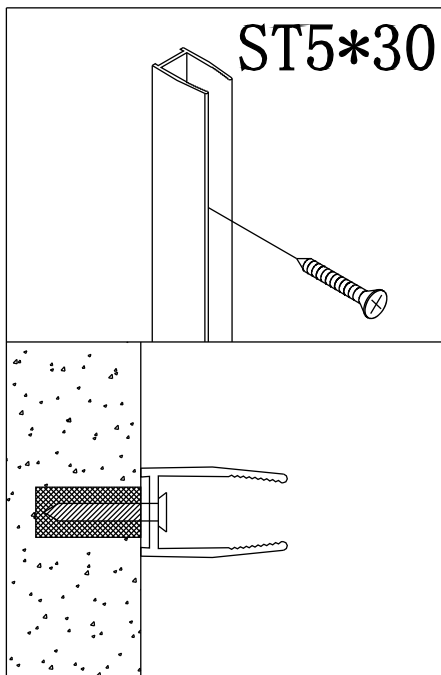

4

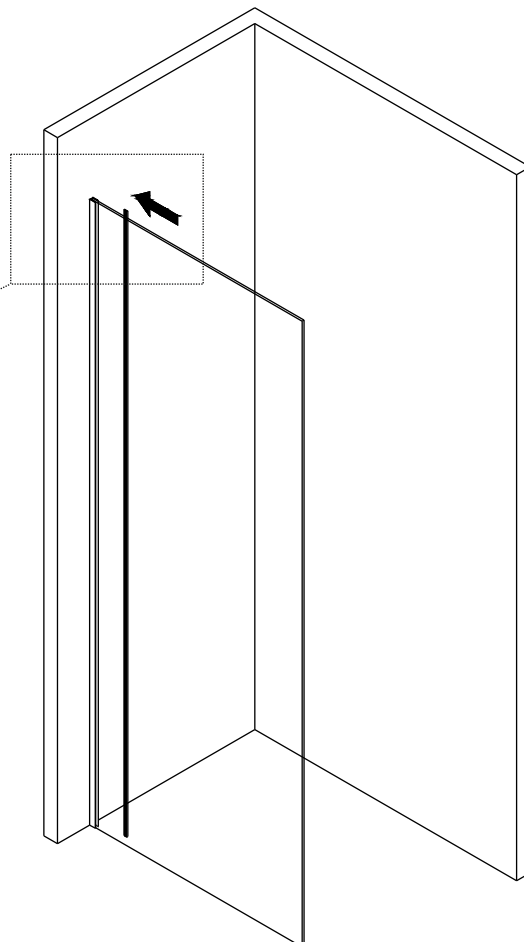
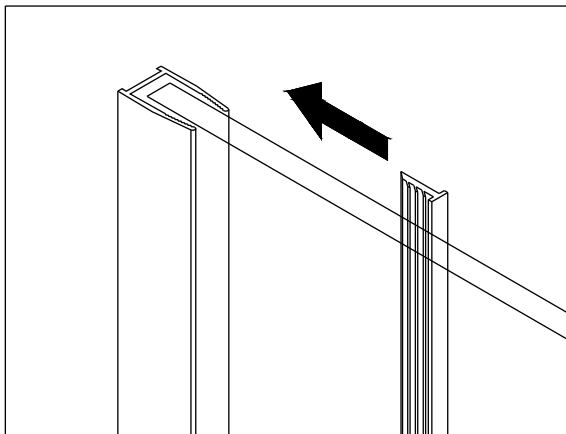

5

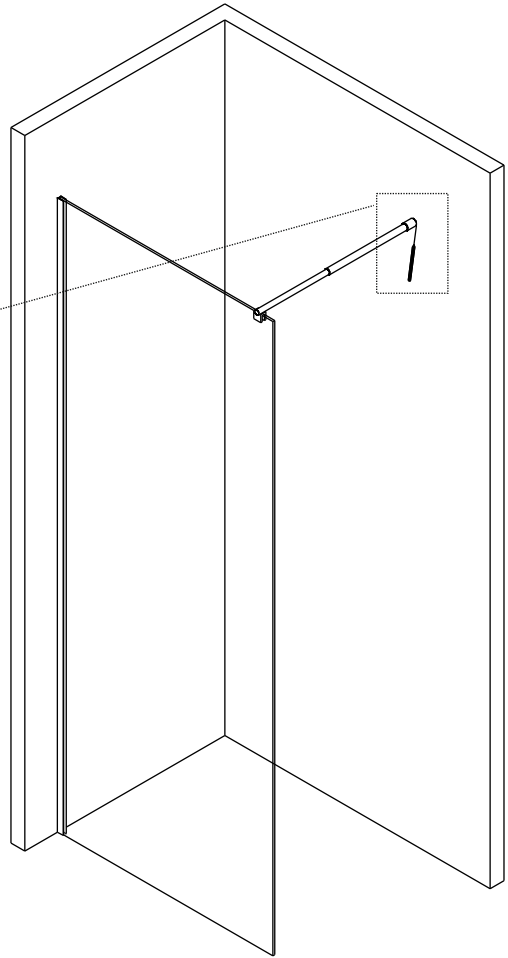
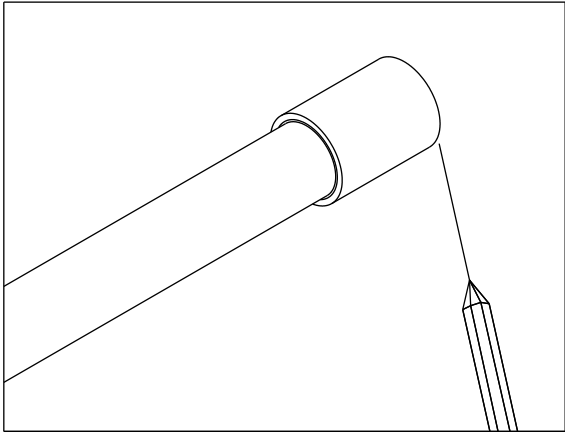

6

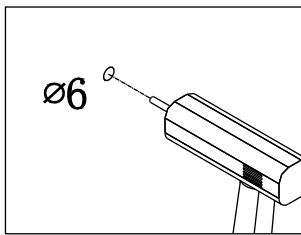
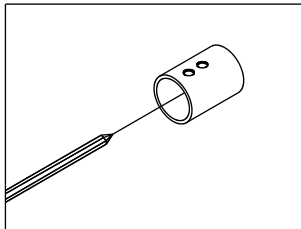

Ø6

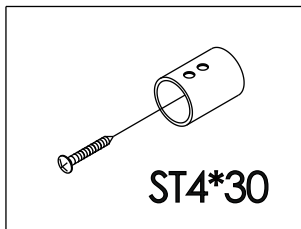
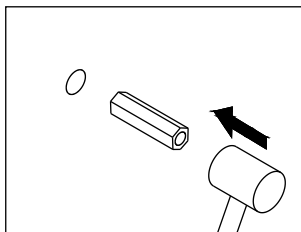

ST4*30

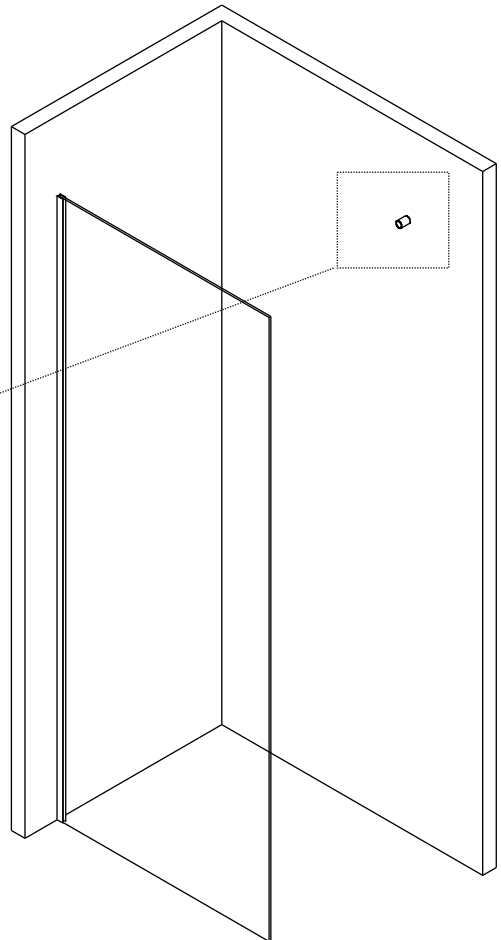

7

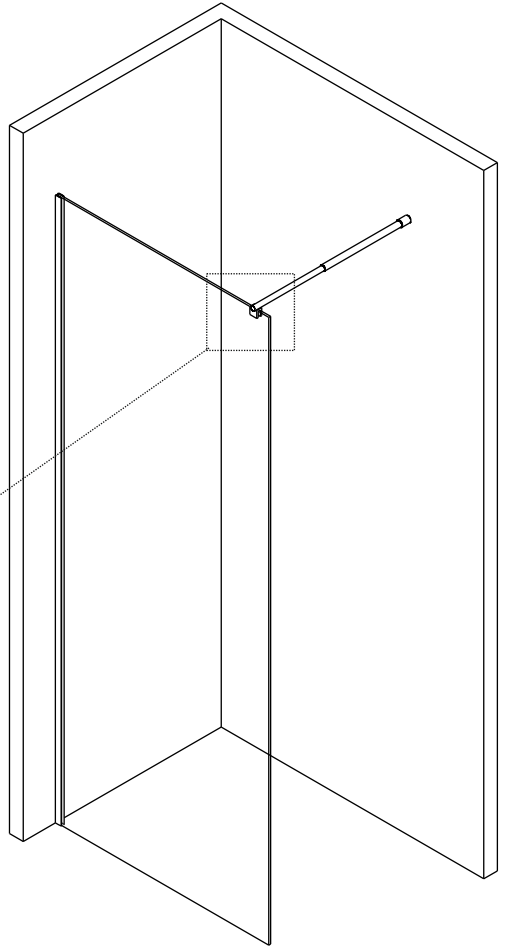
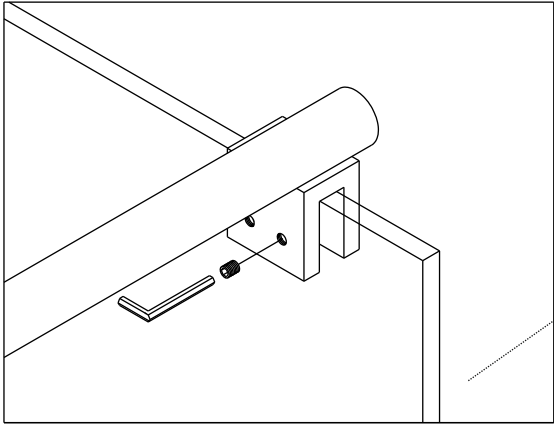

8

A+B

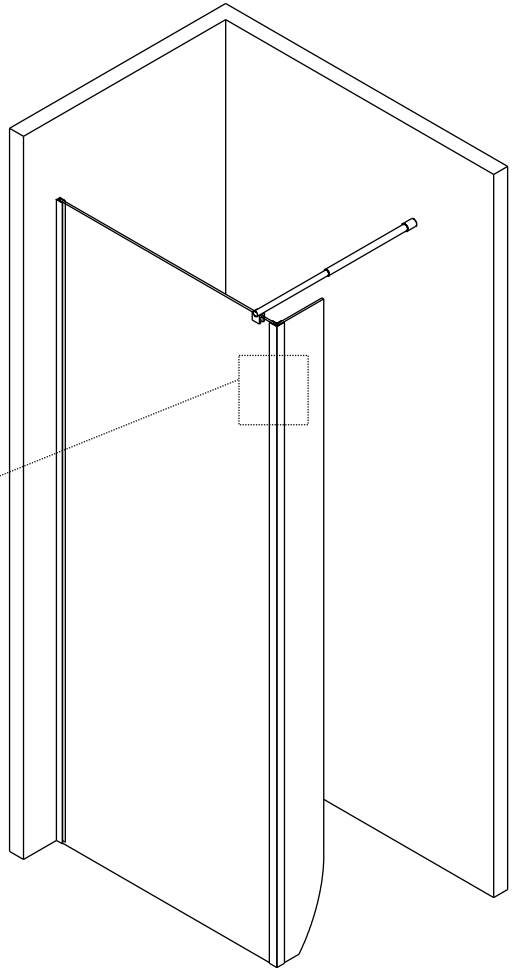
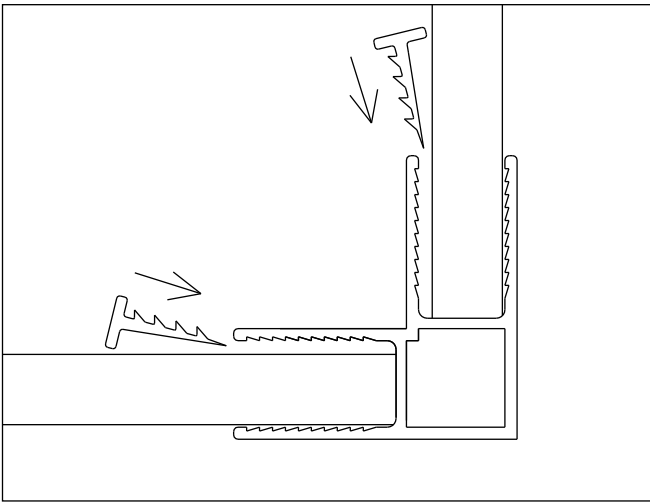

9

A+B+C

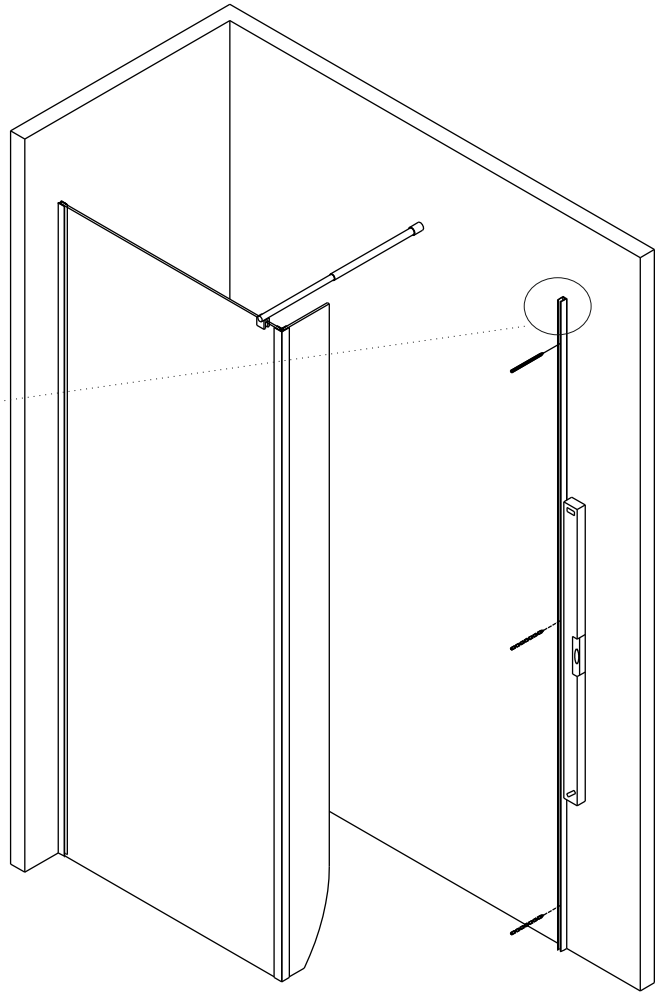
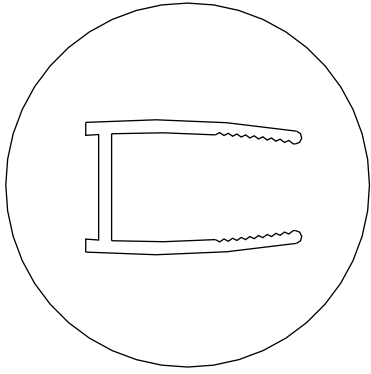

10

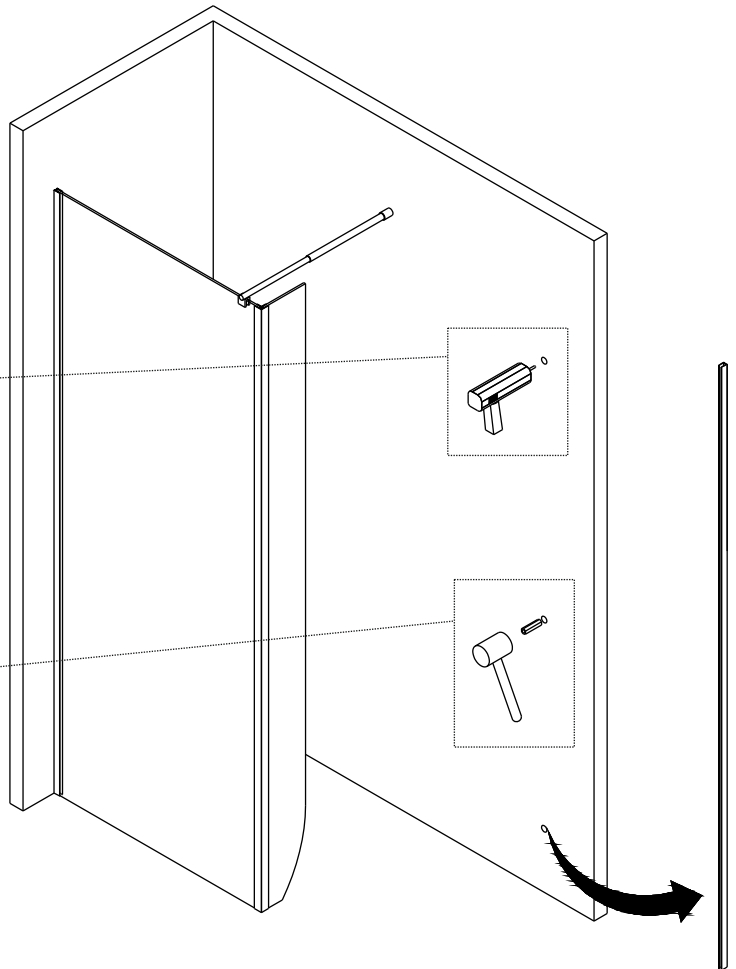
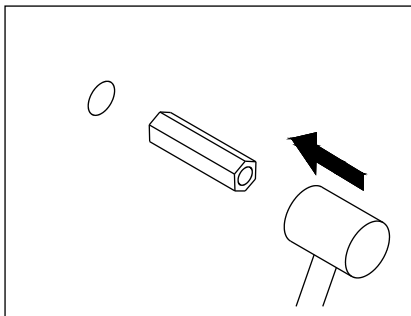
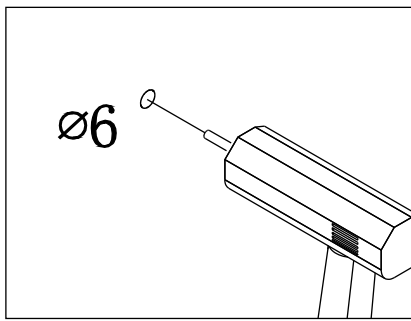

11

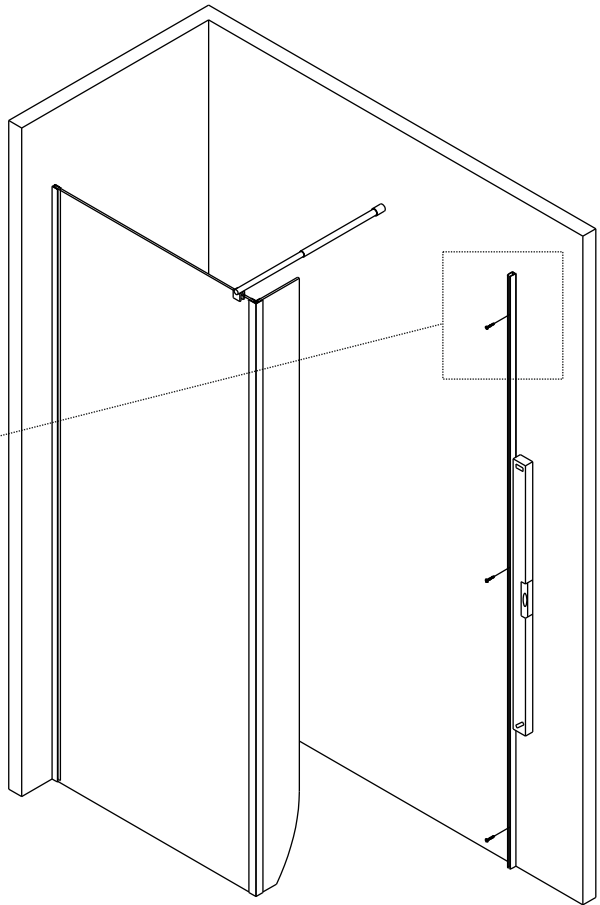
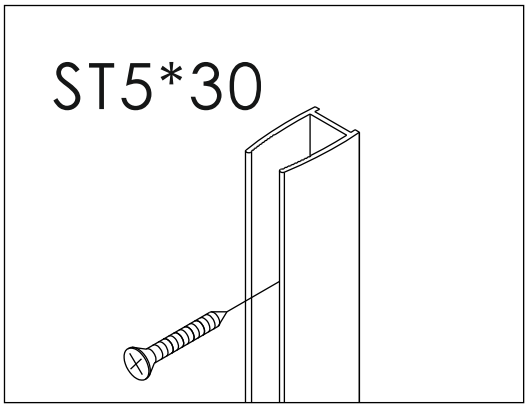

12

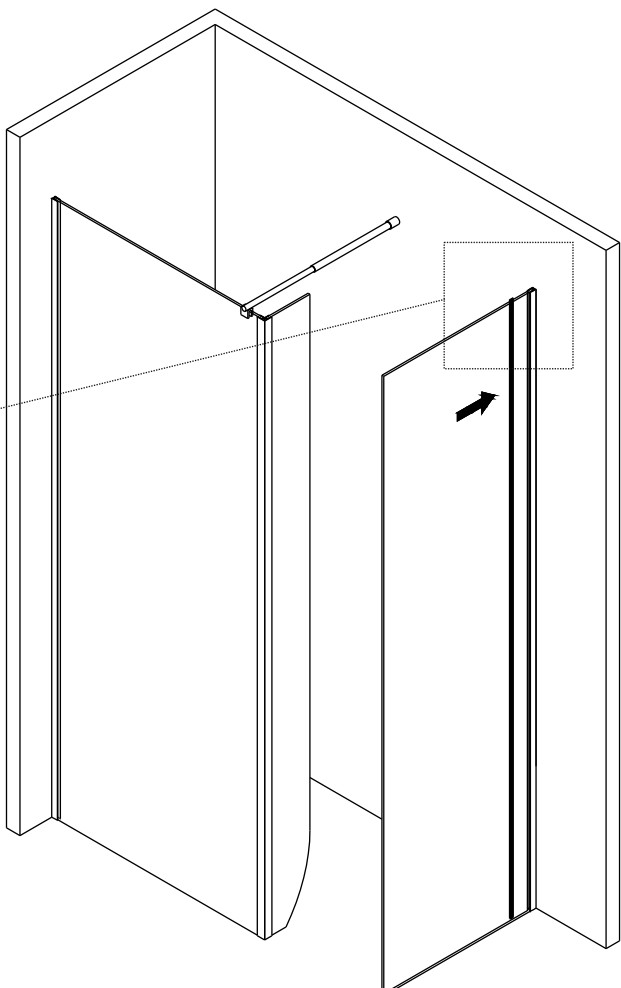
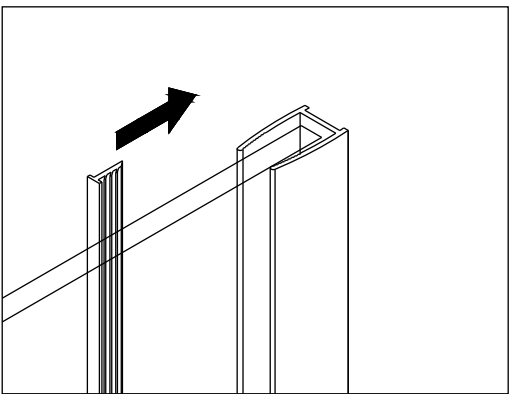

13

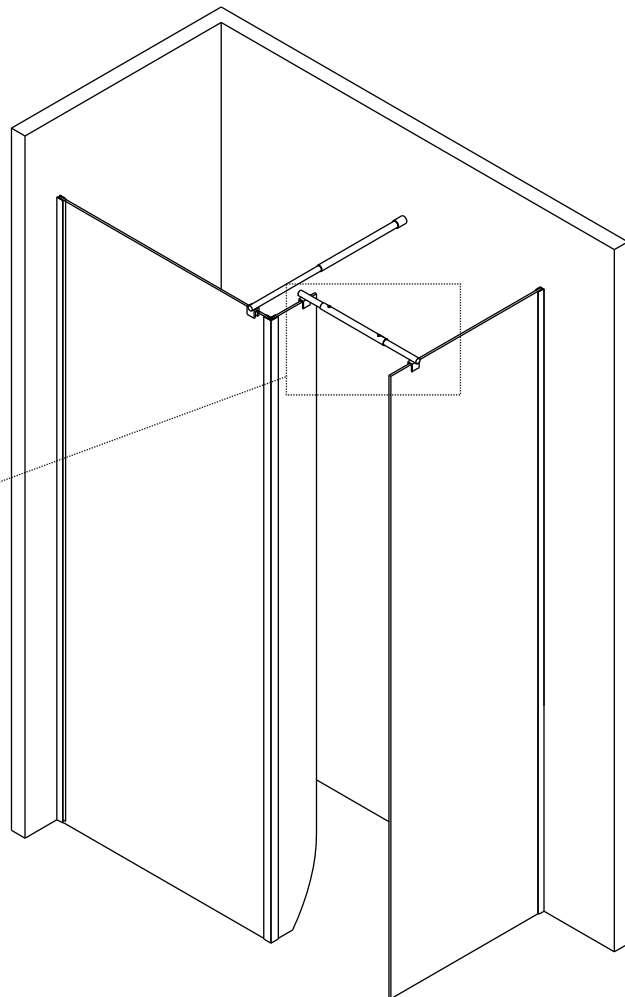
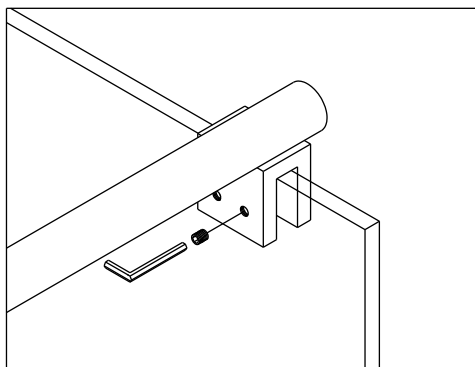
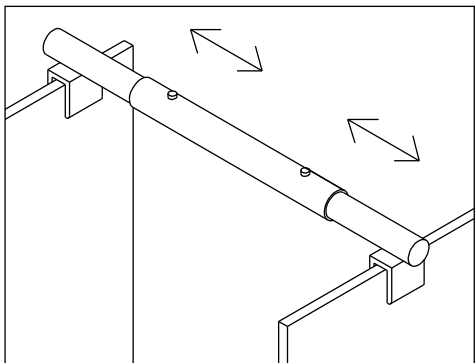

14

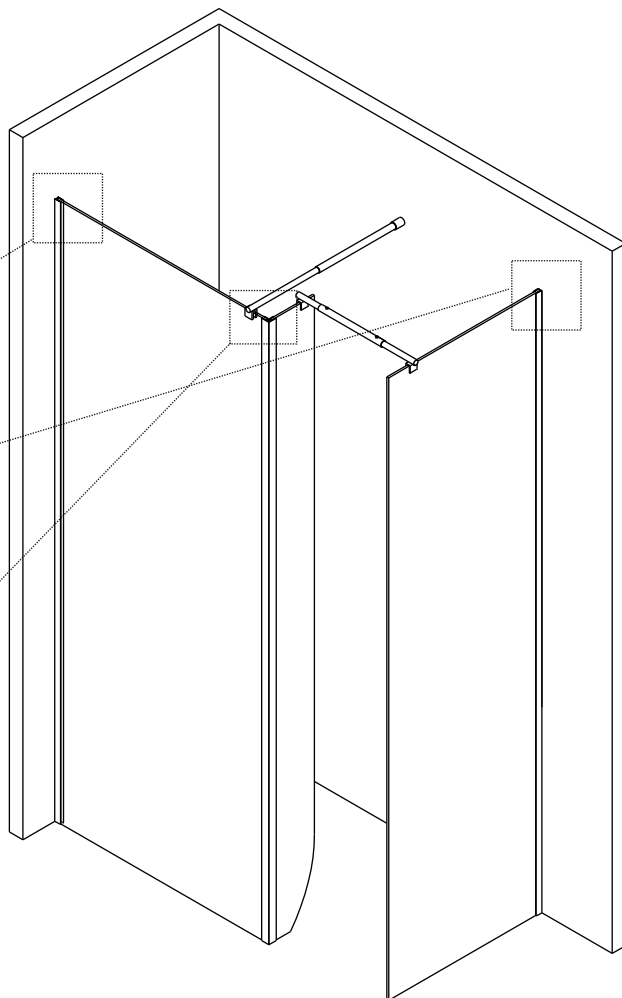
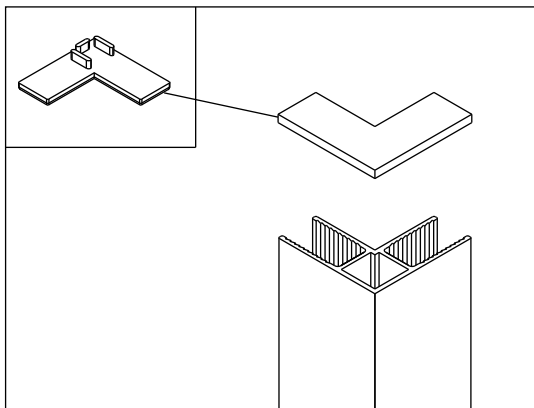
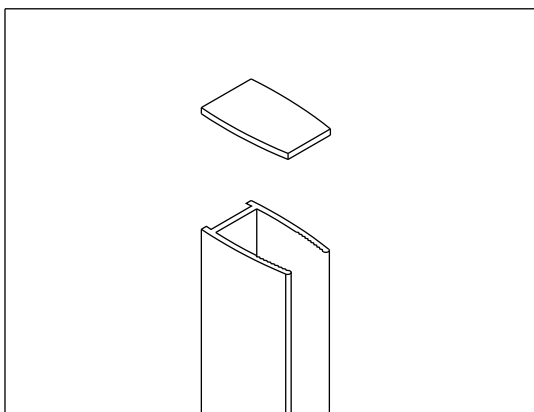

15



Silicone
Silicona
24H

